

# SOLDERING COURSE

W-ZAAL / SMARTSP LAB



Thomas Hoen  
Joep Zanen  
Kasper Müller

# Contents

<b>1 Introduction</b>	<b>2</b>
1.1 Planning . . . . .	2
<b>2 Circuit layout</b>	<b>3</b>
2.1 Decoupling . . . . .	4
<b>3 Soldering on through-hole print</b>	<b>5</b>
<b>4 Jack plug</b>	<b>7</b>
<b>5 Datasheets</b>	<b>9</b>
<b>6 Common errors</b>	<b>11</b>
<b>7 Finding errors</b>	<b>13</b>
7.1 Visual inspection . . . . .	13
7.2 Measuring the voltage at the power leads of the components . . . . .	13
7.3 Tracing the signal through the system . . . . .	13
7.4 Using the ohmmeter/ beeper to find shorts or bad connections . . . . .	14
<b>8 Fixing errors</b>	<b>15</b>
8.1 Solder wick / desoldering braid . . . . .	15
8.2 Desoldering pump . . . . .	16
<b>9 Introduction to the Practicum</b>	<b>17</b>
9.1 Amplification . . . . .	17
9.2 Current buffer . . . . .	18
9.3 Supply voltages . . . . .	18
9.4 Input bias . . . . .	19
9.5 Speaker protection . . . . .	19
9.6 Terminals . . . . .	20
<b>10 Suggested Upgrades</b>	<b>21</b>
10.1 Increase the supply voltage . . . . .	21
10.2 Stereo to mono mixer . . . . .	21
10.3 Class AB amplifier . . . . .	23
10.4 Volume control . . . . .	23
10.5 Bridging . . . . .	24

# Chapter 1

## Introduction

Welcome to our soldering course. We are glad that you signed yourself in. In this document you will find all the information that was treated in our lecture. At last, you can find a guide to solder your amplifier and side information on how the amplifier works.

### 1.1 Planning

During the lecture you will learn about the theory of soldering and the amplifier you are going to build. This lecture will take place at [probably] educafe. This is in the near the Starbucks. After the lecture you will be heading to the W-zaal where you will be putting your newly acquired knowledge to the test by planning your circuit layout and soldering your audio amplifier.

## Chapter 2

# Circuit layout

The most important part when you try to design a circuit layout is to think carefully about it. A thought-out plan makes the soldering easy and minimizes the chance of errors. Proceed as follows:

- Study the packaging and the datasheets of the components you're going to use and figure out their pin-out and polarity.
- Place the components that are to be connected closely together and take in account that some parts can be quite big (for example, capacitors or heat sinks for transistors)
- Always use an IC socket for the ICs you're using. By doing so, you can't overheat the sensitive IC when soldering, and you can replace the thing easily when you accidentally blow it up.
- Watch out for polar components (capacitors, diodes, LEDs, everything with more than two leads). There is only one way to connect them correctly. Also make sure that the "dot" on the IC and it's socket are aligned.
- Keep your layout logical and not too small. You will be thankful later for doing this when you're troubleshooting.
- Consider how you are going to connect the components. (You'll read more about this later)
- Check everything! Does everything fit together nicely? Can you desolder anything if you have to? Does it look logical?

There are computer programs that can help you with your circuit layout. However, you will always have to create the big picture by yourself, or the software will make a mess of things. You have to know what you are doing!

## 2.1 Decoupling

Decoupling is the placement of capacitors to limit voltage fluctuations within a circuit. This is mainly done in power lines, so for example between the  $V_+$  and Ground, or the  $V_+$  and  $V_-$ . There are several reasons why this will come in handy:

The power demand of a circuit can vary over time, and the power supply will not be able to anticipate immediately because of the internal resistance of itself and the circuit. Because of this resistance (yes, your tin paths have resistance too!), it's important to place the decoupling capacitors as closely as possible to the part that uses the most current. When the circuit is temporarily using less power, the capacitor will store the excess, and when the circuit is temporarily using more power, the capacitor will provide it. By decoupling, you ensure that the power lines are much more stable.

Though this the internal resistance is more dominant in non-idealities of your wiring, every piece of metal also is more or less working as an antenna. Every tin path or wire in your circuit or the power supply works like this, and therefore will receive signals you don't want in your circuit. If you have decoupled properly, the signals are grounded by the capacitors and will not be a problem anymore.

In the application of an audio amplifier, decoupling is very useful (and very audible!), because the power consumption will fluctuate depending on the music you are amplifying. If you don't decouple properly, your volume will fluctuate with the power consumption of the circuit. You will hear this mostly with low frequencies, because bass tones draw the most power from your amplifier and thus will use lots of current. If the circuit is not properly decoupled, your bass is gone or very quietly audible because of the voltage drop.

Two sorts of capacitors are used for decoupling, a big one and a small one. The big electrolytic capacitor (ELCO) has a large capacitance, but quite a lot internal resistance and inductance, which causes it to work poorly at relatively high frequencies. The small ceramic capacitor has a lower capacitance, but works much better at these frequencies. Connecting an ELCO and a ceramic capacitor in parallel will give the advantages of each of the capacitors.

## Chapter 3

# Soldering on through-hole print

During most projects and during this course through-hole prototyping boards are used to solder on. These boards contains metal holes where the components are placed in. This type of component mounting is called 'through-hole'. The components are inserted into the holes and soldered on pads on the other side of the board.

When soldering on a print it is easiest to solder the central components first. Some components like resistors will need their legs bent to place the component on the print. Be careful, if you bend the legs to many times, they will break. When the component is placed on the print, it is a good idea to bend the legs a little bit in opposite directions to keep the component in place (see figure 3.1). Do not forget that some components like diodes and electrolytic capacitors are polarized and have to be placed in the right direction. Figure 3.2 shows how to and how not to mount components to a print. With the exception of some transistors, unless otherwise specified, all components should be pressed down flush with the surface of the board as far as they will go. Note that it is better not to let components touch that should not be connected.

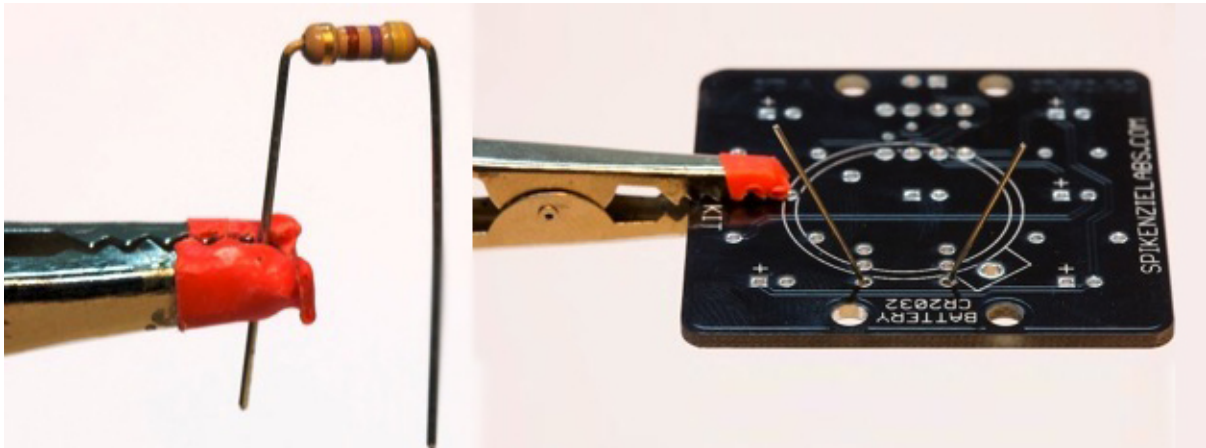

Figure 3.1: Bend the legs of the component a bit to keep the component in place

There are different types of tin to solder with and they all have different melting points. Most types melt around 220°C, so the ideal temperature to set your soldering iron is between 250°C and 300°C. When soldering, be careful not to overheat components or touch plastics with the iron, because most plastics also melt at these temperatures. Keep in mind that inhaling all these plastics is not considered to be a healthy activity.

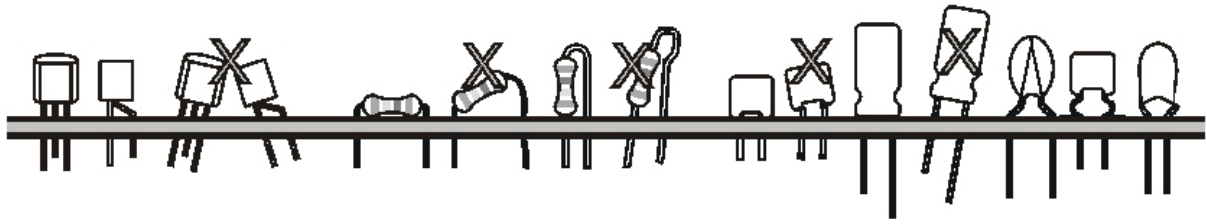

Figure 3.2: How and how not to mount components on the board

In industrial environments it is forbidden to use lead-bearing solder. Lead-free solder has a higher melting point than regular lead-bearing solder, so higher temperatures are needed in order to solder which makes soldering a lot harder. Fortunately, in this course you will use normal lead-bearing solder, but produces soldering smoke which contains lead. This is also not healthy, and we do not recommend inhaling this.

Most (modern) solder contains flux, a substance that cleans the metal and causes the solder to flow more easily. This substance is present in the core of the solder wire. To prevent disturbing the proportions of flux in the ends of solder wire, never tear solder wires, but cut them.

Place the soldering iron on the ring of the through-hole print, the pad, in a way it also touches the component leg, so heat is transferred to both the component leg and the pad. Wait a two seconds to heat the metal. Apply the solder on the other side of the pad, after the components are heated. The solder will melt and flow around and in the joint, creating a solder joint between the component leg and the pad. Do not apply the solder to the tip of the iron and bring it over to the pad. In this way the flux will vaporize before the solder touches the pad. In that case, the solder will not flow neatly around the pad, resulting in bad solder joints. Also do not keep the iron on the pad too long because it can overheat the component or detach the pad from the print. Add just enough solder to form a small rising filled around the component leg. When the component is soldered to the print you can cut the component legs, but be careful not damaging the solder joint.

**After the joint is hot (~2 secs.)  
apply solder AT the joint and  
then allow a SMALL amount to  
melt and 'flow' into and around joint**

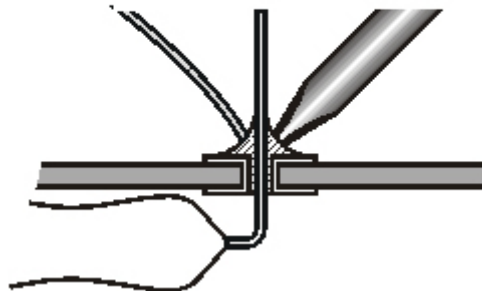

## Chapter 4

# Jack plug

To connect the amplifier with the source, a connector is needed. In this course you can use a Jack plug. A Jack connector is a common family of connectors typically used for analog signals including audio.

There are several Jack connectors available: 2.5mm, 3.5mm, 6.35mm. This time you use a 3.5 mm stereo Jack. This connector has three contacts. They are called: Tip, Ring and Sleeve. In the picture below you can see the connector.



Figure 4.1: 3.5 mm stereo jack

**IMPORTANT:** you only use 2 contacts for this amplifier (Tip and the Sleeve), because we are going to build a mono amplifier, so we can only use one input signal for this device. You can see in the figure what the functions of the connections are.

If you do not know for sure which contact is the Tip, just measure the resistance between the soldering contact and the Tip. The connection of the plug to the soldering contacts differ per producer, to make sure to check this.

The most practical wire to use with a jack plug is stranded audio wire. This is one cable, with two separated conductions in it: one on the inside, and one surrounding it. The surrounding conductor also acts as shielding for noise, thus keeping your signal quality higher.



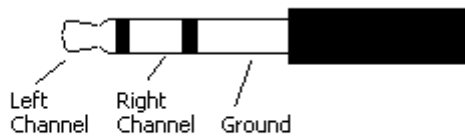

**Connection diagram for standard stereo headphone plug**

Figure 4.2: Stereo jack diagram

In steps, this would be the most common way to solder a jack plug to a cable. First make sure to place the plastic cover around the cable. Now, strip the outer isolation (picture 1 below). Then cut half of the strands off, and twist the remaining strands together (picture 3). Now, strip the inner insulation and twist these strands together (picture 3) and coat these wires with tin (picture 4). After this, push the tinned wires through the corresponding soldering contacts (the outer shielding connects to the ground of the plug) on the jack plug and solder them. You can now cut off any wire leftover wire outside the connector, and bend the plug around the wire. The result would be something like picture 5. Please notice the connection of the red wire can differ per manufactures, as already mentioned. Last, screw the plastic cover around the internal connector (picture 6).

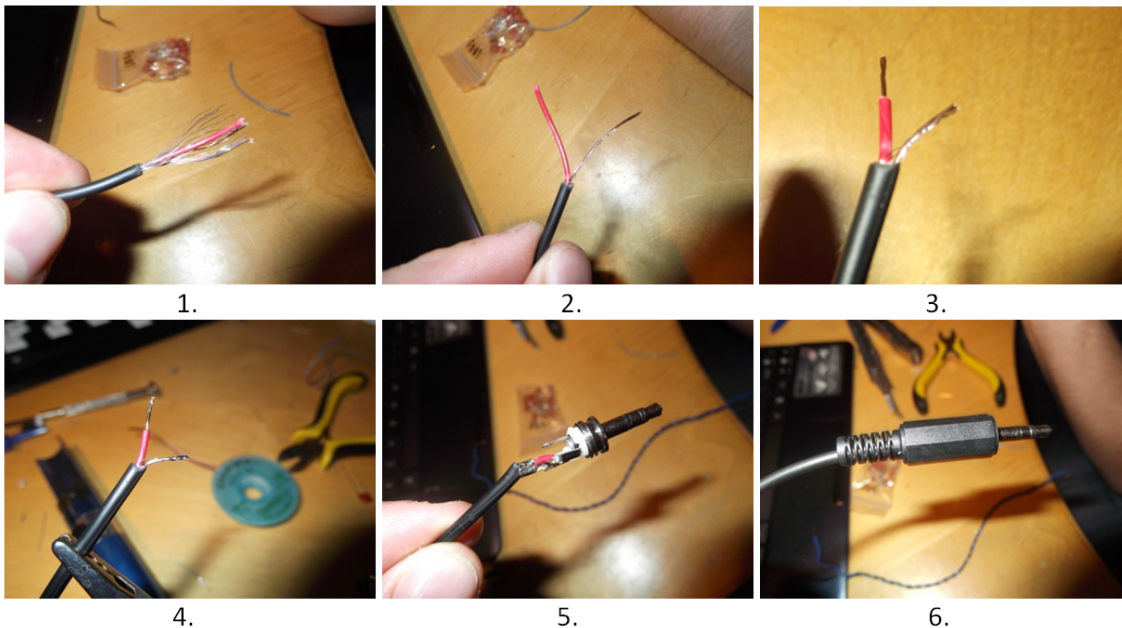

# Chapter 5

## Datasheets

There are many different components that can be used in a circuit. For some components you will know directly what they do, for others it may not be clear at first hand. When you design a circuit you want to know what a particular component does. This is what datasheets are for.

A datasheet contains all the information about the component you want to use it in a circuit. Most datasheets will contain the pin layout, max and minimum voltages, current limitations and speed limitations. There will be a lot more information in the datasheet depending on the component itself. The datasheet of an op-amp can include its frequency response, while the datasheet of a microcontroller will contain information about its functionality.

In most datasheets the first pages are used to give a summary of the component. It will contain its function, maximum ratings, pin layout and some scenarios you can use the component in. The rest of the pages of a datasheet will contain detailed information about the component. There is no need to read all these pages, instead read only the relevant parts for your circuit.

In datasheets of ICs the positive and negative power supply can have various names. They are shown in the table below.

Positive power supply	Negative power supply
VDD	VSS
VCC	VEE

Some components like transistors are made by many manufacturers. Some of these manufacturers will have a different pin layout than other manufacturers. It is advised to look at the datasheet of the manufacturer of the component you have to prevent errors in the pin layout of your design. In figure 5.1 the names of the terminals of the transistors are given.

When you look up the pin layout of an IC you will see something as shown in figure 5.2. Notice that the circle at the top of the IC corresponds to the circle on a physical IC, see figure 5.3.

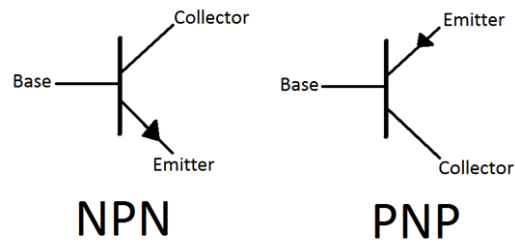

Figure 5.1: Names of the terminals of an NPN and a PNP transistor

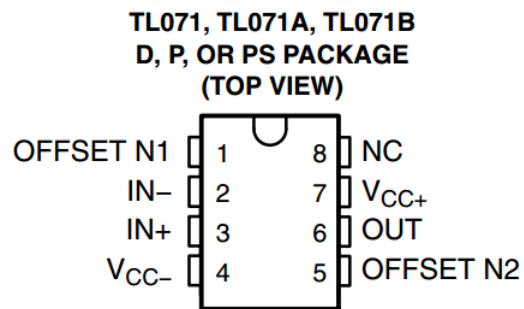

Figure 5.2: Schematic of an opamp

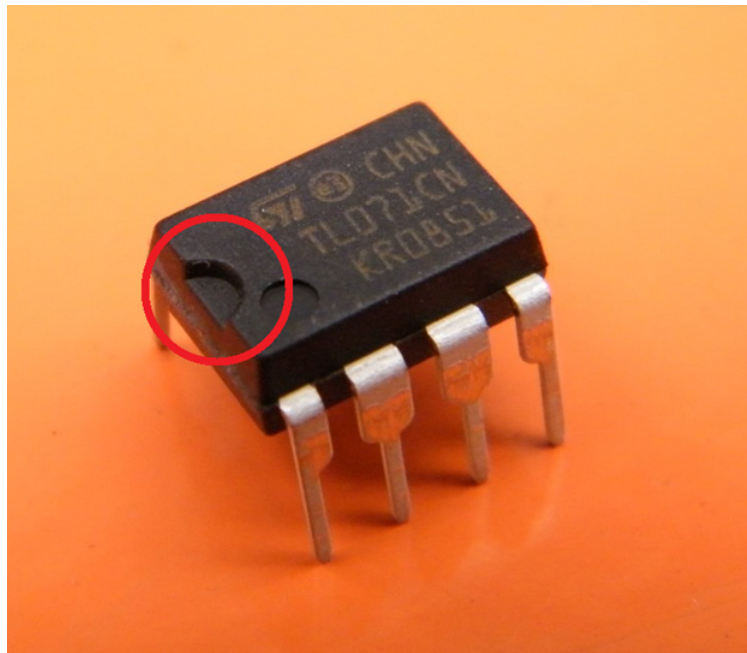

Figure 5.3: Real opamp package.

## Chapter 6

# Common errors

When you are soldering your own projects, there are a lot of things that can go wrong, so be careful. The first thing that could go wrong are missing connections. In your electrical engineering life you have to make a lot of connections between the different parts of the circuits. It is very easy to forget a connection. The best thing is to work step by step.

Concentration is important when soldering a circuit. If you get distracted, wrong connections are easily made.

A good soldering iron is also important to make nice products. The most common defect when hand-soldering results from the parts being joined not exceeding the solder's melting point, resulting in a "cold solder" joint: a joint that seems to conduct, but in fact, does not. This is usually the result of the soldering iron being used to heat the solder directly, rather than the parts themselves.

Properly done, the iron heats the parts to be connected, which in turn melt the solder, guaranteeing adequate heat to be applied to the joined parts for thorough wetting. In electronic hand soldering the flux is embedded in the solder. Therefore heating the solder first may cause the flux to evaporate before it cleans the surfaces being soldered. A cold-soldered joint may not conduct at all, or may conduct only intermittently.

If all metal surfaces are not properly fluxed and brought above the melting temperature of the solder in use, the result will be an unreliable "cold solder joint". For an example, see the picture below. So make sure that your iron and also the joint are at the right temperature.

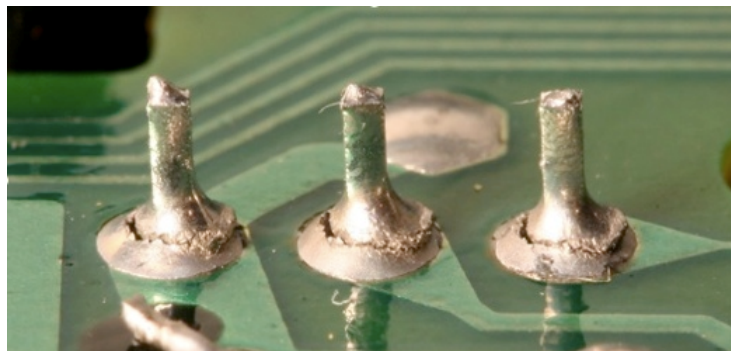

Figure 6.1: A cold joint

A "dry joint" occurs when the cooling solder is moved, and often occurs because the joint moves when the soldering iron is removed from the joint.

It is also possible that you have made a shortcut. There is a possibility that this will destroy a component.

By soldering your components it is important to pay attention to the polarity. Especially soldering electrolytic capacitors (ELCO) often go wrong. The best way to recognize the negative pole is to look for the minus sign or the white strip on a ELCO. For an example, see figure 6.2.



Figure 6.2: Elco pin layout

# Chapter 7

## Finding errors

If you have paid close attention to the previous chapters, you've hopefully built up your circuit correctly, but usually when you power up your circuit it doesn't work as intended. Your circuit can fail in two ways, either you see smoke escape, or it just doesn't work without self-destructing.

In the first case, since you've probably hooked up your system to a lab power supply, you had better leave the circuit powered on and determine where the smoke is coming from, because the component which produces the smoke is likely broken anyway. The place from which the smoke escapes is most probably the place where the issue lies.

In the second case, you are probably deeper into the woods. Finding an error in this case can be done in many ways, but we'll list a few ways that will work most of the time.

### 7.1 Visual inspection

The easiest way to find problems is visual inspection, if you know the printouts of your components and your circuit well, you can often find issues just by looking at the soldered circuit. A short circuit or a component which isn't completely connected yet, are often easy issues to spot.

### 7.2 Measuring the voltage at the power leads of the components

A common cause of failure is a wrong voltage at the power leads (i.e.  $V_{cc}$ ) of the component. This generally can be found using a multimeter, but in more obscure cases where stability of the power-lines is important, issues can also be found by using the oscilloscope.

### 7.3 Tracing the signal through the system

Often you can divide your system up into subsystems, by measuring the signal at the beginning of each subsystem, you can narrow down the location of the issue. Often you would do this by using an oscilloscope, but sometimes a multimeter will suffice. A good hint is to determine of the op-amp is doing what it should do: measure the voltages at the inputs, determine what the output should be and then measure the output to see if it is correct. If it is not correct, the opamp is either powered incorrectly or broken. The latter case is most often caused by the first case.

## 7.4 Using the ohmmeter/ beeper to find shorts or bad connections

If you have found the general location of the issue you can use the ohmmeter to find low resistance paths to other lines. Make sure to switch the power over your circuit off, or the multimeter will not function correctly. A way to trace the short is using 4-wire resistance measurement, this is a way to measure very low resistances. This is not a function you find on many multimeters, but the multimeters in the W-zaal do have this option. 4-wire resistance measurement has the advantage over 2 wire measurement that the resistance of the measurement-leads is not measured. This allows for greater accuracy in low resistance measurements. You can trace the location of the short by looking for the position of least resistance.

However, you can also use the beeper, this is often the secondary function of the diode measurement of any multimeter. The beeper allows you to keep looking at the circuit while you look for a fault. The speaker in your multimeter will give a beep in case you have found a short between your measurement leads. The number which the multimeter indicates in this mode is the voltage differential caused by the current which the multimeter forces through the wire. Sometimes because the threshold is not reached the multimeter will not beep even though there is a rather low resistance path to another line.

# Chapter 8

## Fixing errors

Perfboard or protoboard is not very durable, so when you try to fix mistakes you have to take care not to destroy it by overheating, or by applying excessive mechanical force.

If you have found a bad connection, for instance a cold joint, you can reheat the connection and add some extra solder. However, you have to take care not to overheat it because as stated above protoboard is not that durable.

If you find, you have soldered a component in the wrong direction or place or you find a short, you have to remove some solder. This is because if you try to remove a component by heating up one side and pulling it out, you risk pulling up the copper-islands on which you try to solder. For removing solder there are two easy tools, the first a desoldering pump, the second solder wick.

### 8.1 Solder wick / desoldering braid

The other, and in some cases much better tool, is solder wick. This is a string of woven copper. This string when heated (with the soldering iron) while in contact with the solder, will melt the solder and then suck the melted copper into the solder wick. This has an advantage over the pump in that this method is much more refined. You have much more control over the amount of solder which you suck away. This comes of course with a downside: the soldering wire is one-use-only, so you have to clip the used part of once you've used it.

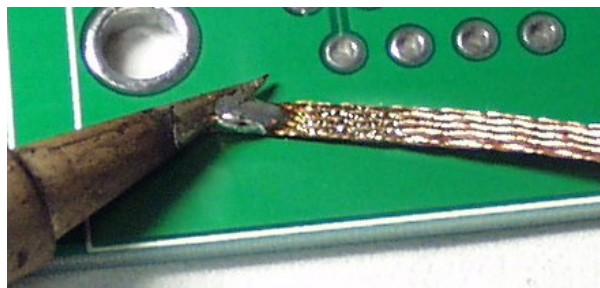

Figure 8.1: How to use a solder wick



## 8.2 Desoldering pump

A desoldering pump uses airflow to suck molten solder away. To use it most effectively you have to melt the solder first, then get the pump as close as possible and release the spring. The molten solder then gets sucked into the pump, however you have to clean the pump by compressing the spring again, because if you don't, the time you want to use it again you will find the pump clogged.



Figure 8.2: A desoldering pump

## Chapter 9

# Introduction to the Practicum

In this course, the final goal is to correctly layout and assemble an audio amplifier, using the techniques you have learned over this evening. This section covers the functionality of the audio amplifier.

### 9.1 Amplification

The audio amplifier is based around a TL071 operational amplifier. In this case, the operational amplifier, with the aid of two resistors, amplifies the incoming signal with a fixed factor 34. With most input devices, for example an mp3 player, the max input volume will result in a little more than the maximum output volume of the amplifier. Until now we have the following schematic:

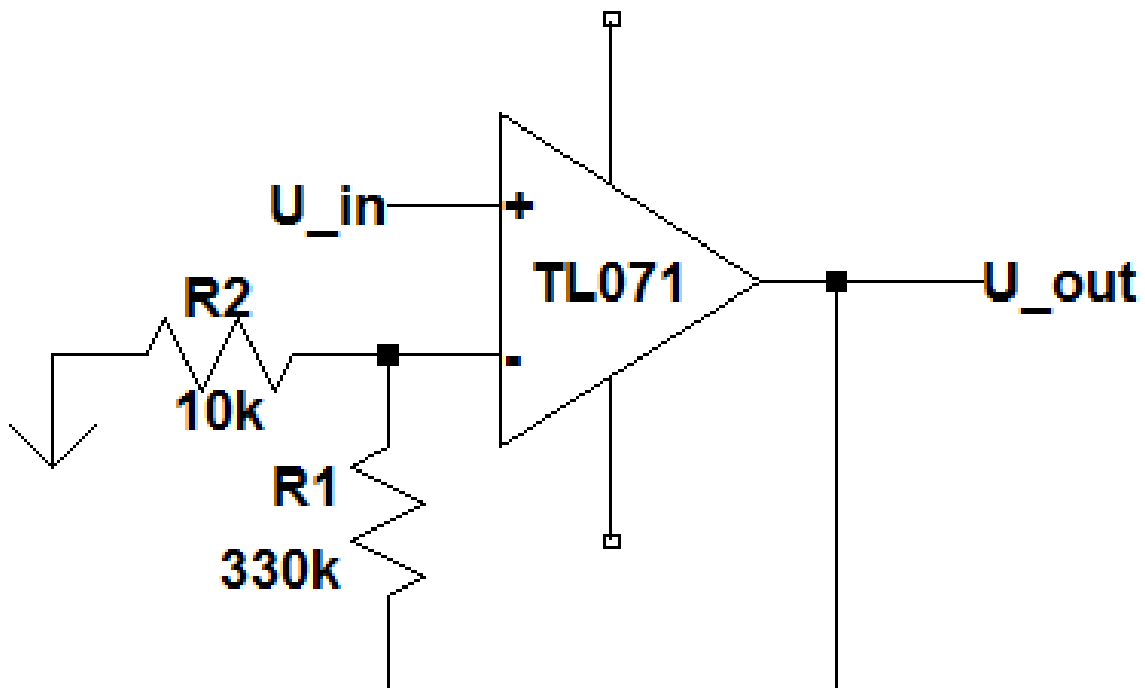

When you solder the final amplifier (not this one above!), use an IC socket for this operational amplifier and be sure to check the datasheet for the pin layout. We can now add anything directly after the operational amplifier; the operational amplifier will make sure the voltage on its input terminals is equal, so the amplification before the resistors is always  $34 * U_{in}$ .

## 9.2 Current buffer

When using a speaker at normal volume, the currents through a speaker are in the order of 100mA AC up to several amperes in louder amplifiers. The typical maximum output current of an operational amplifier is 20mA. Furthermore, the resistance of a speaker is typically 4 or 8 ohms, whereas the internal resistance of the output of an operational amplifier is in the order of tens of ohms, so the operational amplifier has too much internal resistance to drive a speaker. We can conclude from this that an operational amplifier is not suitable to directly drive a speaker. In this case we add a so called "push-pull pair" between the operational amplifier and resistors. This amplifier part or 'stage' acts as a buffer for the operational amplifier, which can drive the speaker. We now get a schematic as:

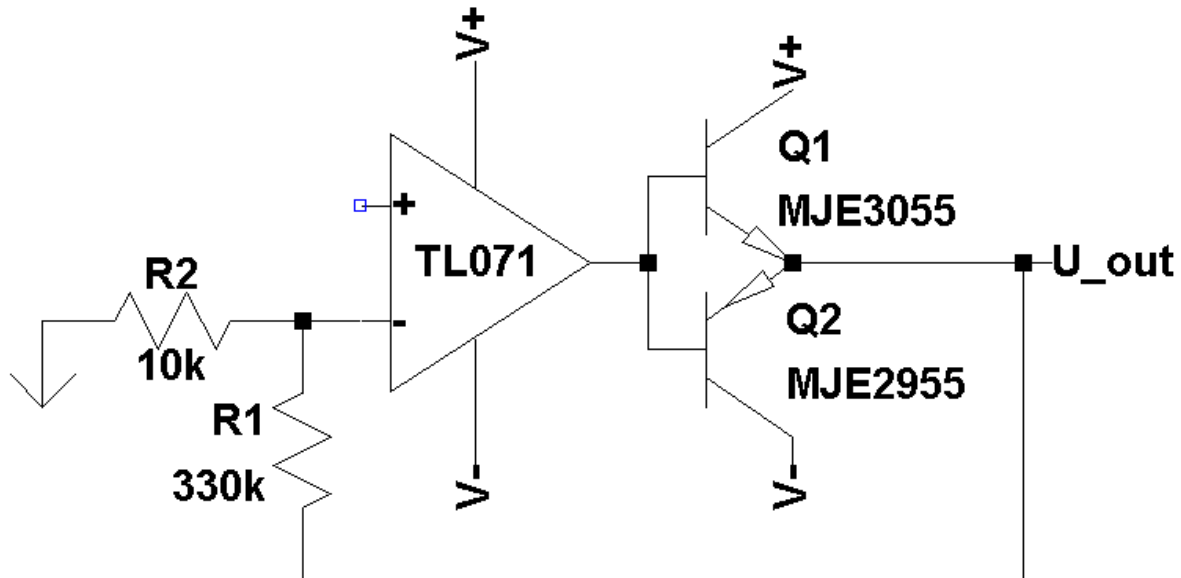

This push-pull pair consist of two transistors, which together form another amplification stage with an amplification factor of 1. This amplification is not really linear, but shows switching characteristics on each flank, but due to the feedback point after this stage, the operational amplifier corrects all these effects.

## 9.3 Supply voltages

Until now we can see three supply voltages:  $V_+$ ,  $V_-$  and a ground. To be able to supply this system from a single power supply, we need to create one of these voltages. It is rather easy to create a voltage between two other voltages, so in this case the "ground" is created with a resistor divider between  $V_+$  and  $V_-$ . Using a voltage divider, we have now created another voltage supply, with a certain internal resistance, think of the Thevenin model. As long as this internal resistance is much lower than the load resistance of this voltage line, this will work as a fixed voltage. To make this "virtual ground" even more stable, decoupling (see part 3: decoupling) is used. This decoupling works for the positive supply line at the same time. Some of these capacitors are electrolytic and therefore subject to polarity. Make sure to solder them the correct way on the print. For now we will use an external supply voltage of 12V. Adding this to the previous circuit diagram will result in:

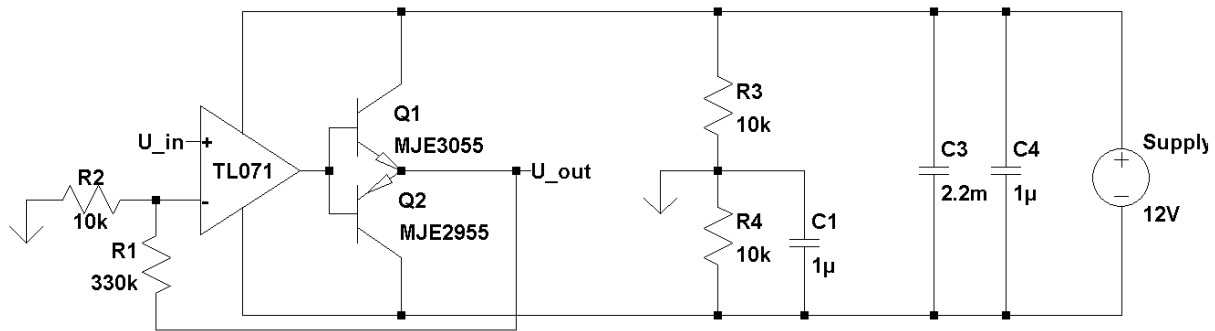

## 9.4 Input bias

The next step in this schematic would be to add an incoming signal. To avoid short circuiting parts of the circuit through the grounding of the voltage supply and the audio source, the safe choice is to keep the negative voltage of the amplifier the same as the mass (common reference and ground) of the incoming audio signal. This presents us with the next problem: the audio is now an AC signal around 0V. For the circuit to work, all signals need to be within the supply lines at all times. The best choice here would be to give the audio a DC offset, so the equilibrium will be around the virtual ground. This can be done by filtering out the incoming DC component and only let the AC pass: a high pass filter. With correctly chosen values, the audible spectrum will pass the filter, while the capacitor charges on the other side to the voltage of the virtual ground. This will result in the next schematic:

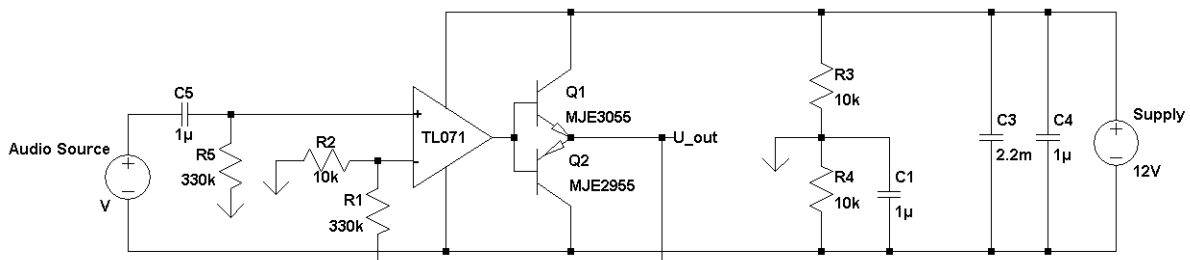

This RC high pass filter has its cutoff frequency at 0.5Hz, so it has minimal influence on the audible spectrum. The resistor has a high enough resistance to be a load to the virtual ground, which is not stable with low impedance loads

## 9.5 Speaker protection

The last thing to add to the schematic is a terminal to connect the speaker to. There are multiple ways to do this, and considering that daddy has expensive speakers, we need to make sure we do this in a correct way. The speaker can be connected between  $U_{out}$  and the negative voltage supply (the virtual ground cannot handle low impedant loads). The problem now is that the voltage over the speaker is some AC signal with an offset of 6V. An offset 6V over an 8 ohm speaker will result in 9 wasted Watts and possibly even damage to daddy's speaker. A very easy way to get rid of this offset is to use another high pass filter, and since the speaker is a resistor itself, only an additional capacitor is needed. Keep in mind that this filter has to let the entire audible spectrum pass in order not to influence the sound of the amplifier. With all components, we now get:

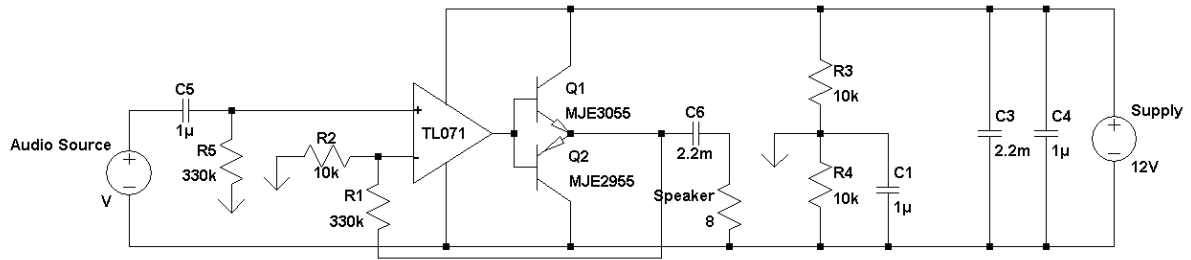

## 9.6 Terminals

The schematic utilizes three external components: a voltage supply, a speaker and an audio source. For the audio source, a mono jack wire will be soldered directly onto the print. The other end will be soldered to a jack plug, using the left channel of the stereo signal. The speaker and the voltage supply are not desired to be connected as permanently as a (in relation cheap) jack plug. For this purpose, a screw terminal (below, left) will be soldered onto the print. When using this terminal in the schematic instead of the voltage supply and the speaker, a final schematic of a basic audio amplifier is made.

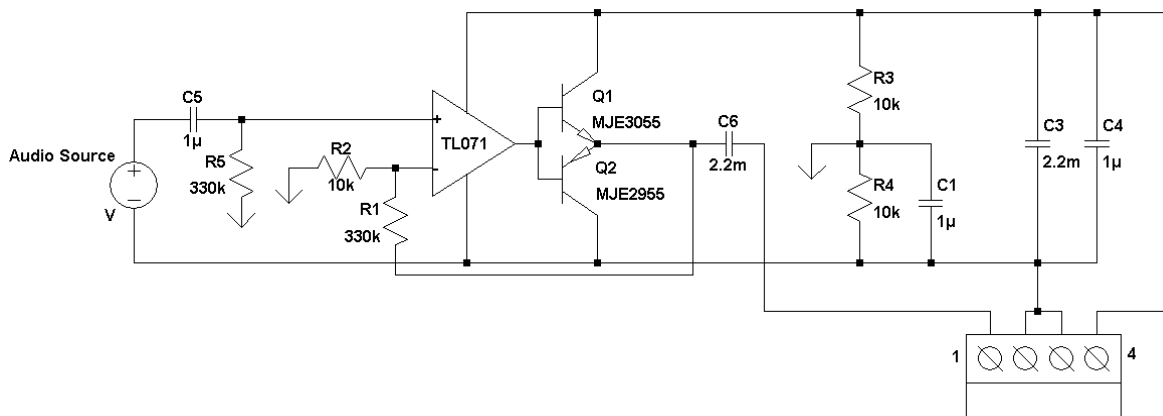

When keeping to this standard configuration of terminals, the external connections can be made as:

Terminal	Function
1	Positive end speaker (red)
2	Negative end speaker (black)
3	Negative voltage supply
4	Positive supply voltage

By now you should have a general idea on what you are soldering and the standard for the connection terminal has been set. Time to put all this theory to practice.

# Chapter 10

## Suggested Upgrades

The amplifier used in this course is one of the most basic amplifier that can be built. It works (at least, when soldered correctly), but is not outstanding in sound quality nor does it have a lot of volume. In this section, some ideas are given to improve the performance of the amplifier with a range of possible upgrades. These upgrades can be used together in any desired combination. Not only will this improve the amplifier, it is also a very informative experience.

### 10.1 Increase the supply voltage

The simplest way to improve your amplifier is to higher the supply voltage. Increasing this voltage will make the amplifier able to produce a greater voltage range -an increased "swing". Since power is related quadratically to voltage, doubling your output voltage will give you four times the output power. There are two things to keep in mind during this procedure:

- More power means that the push-pull pair will dissipate more power and become warmer. When increasing the voltage, monitor the transistor temperature and add heat sinks if necessary. Take the size of the heat sinks into account when making the layout of your print.
- All components have a maximum voltage they can handle. The following components in the schematic below need to be able to handle the following fractions of the supply voltage ( $U_{CC}$ ):

Component	Minimum specified "maximum voltage"
C1 u/u C4	$0.5 U_{CC}$
C5 & C6	$U_{CC}$
TL071	$U_{CC}$

### 10.2 Stereo to mono mixer

The basic amplifier utilizes only one channel of a stereo signal. In most music, however, instruments are (partially) panned to either the left or right channel. In practice, this means that a big part of the mix is not actually in your incoming audio signal. There are two ways to solve this problem:

1. Built the amplifier twice - one time for either channel. Voila, you just built yourself a stereo amplifier.

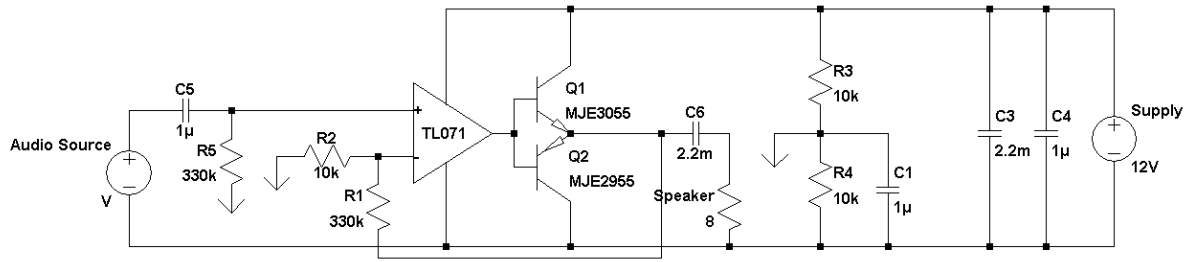

2. Mix the stereo signal to a mono signal.

If you use two equivalent resistors as a voltage divider directly after the input nodes, you will be able to use the output node as the average between the two stereo input signals. Keep in mind this resistor pair will act as a voltage source with an internal resistance, so keep the parallel resistance far lower than the load resistance. Values can be as low as 16 ohms, which equals the resistance of a standard pair of headphones. Suggested value: anything between  $50\Omega$  and  $10k\Omega$ , as long as the two are equal.

When these two resistors (R7 and R8) are added to the circuit, the resulting part of the schematic will become:

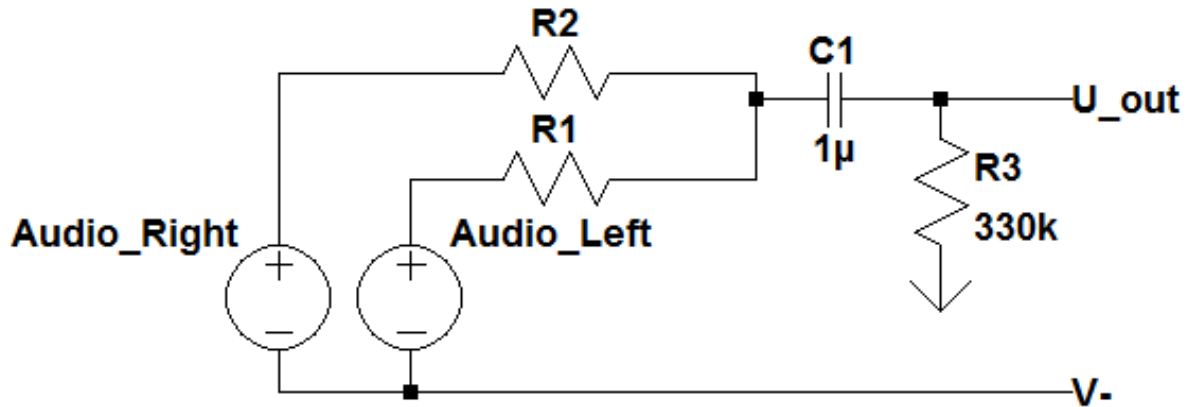

## 10.3 Class AB amplifier

As said earlier on, the push-pull pair shows some switching behavior. Even though the operational amplifier corrects this, there is still some distortion from this effect, called "crossover distortion". This happens when one transistor stops conducting, but the other one is not conducting yet. This margin can be decreased by adding two resistors and two diodes, as seen below. This will create a fixed voltage of 1.4V between the bases of both transistors, thus ensuring that when one transistor stops conducting, the other one starts conducting immediately, thus removing the crossover distortion. The danger of this however, is that both transistors can be switched on at the same time, basically making a short circuit between the positive and negative supply voltage.

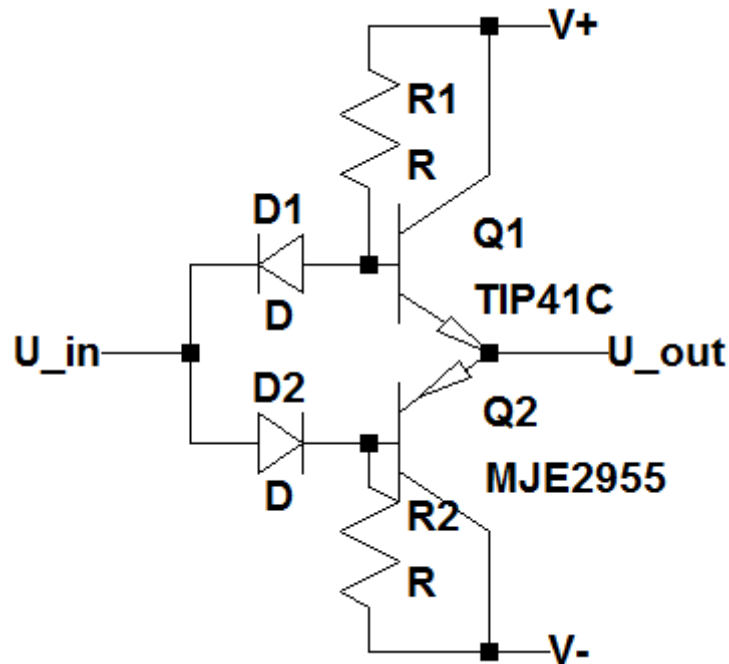

There is another downside to this circuit. To start with, the amplifier will draw a significant current, even in rest. When the diodes badly match the transistors, this current may become as high as several amperes. Furthermore, due to the voltage over R7 and R1, the output swing over the speaker is decreased. When this amplifier is powered at a low voltage, this will greatly influence the volume the amplifier is able to produce. You can correct this by increasing the supply voltage.

## 10.4 Volume control

To start with, the amplifier has a fixed amplification: the easiest way to change the volume would be to change the level of the input device. There are multiple places to place a volume pot (potentiometer). One of them would be directly after the input node. When choosing a suitable pot, keep the following things in mind:

- Once again a voltage source with an internal resistance is created, so pick a pot with a resistance of far less than the input impedance. 10k $\Omega$  is a common value for potentiometers and is suitable for this purpose.
- The human ear works logarithmically, so use a pot with a logarithmic scale for a smooth volume control. When using a 'standard' linear potentiometer, it will seem that the volume increases very fast in the lower half of the rotation, and the pot has almost no influence in the upper half of the rotation.



- This pot can only lower the volume, to go louder you will have to adjust the values of the resistors in the feedback loop.
- When using the stereo to mono mixer as well, add this pot after the voltage divider. Also make sure that the resistors of the monifier have a much lower value than this pot. Suggested values for the resistors in the stereo to mono mixer:  $50\Omega$  to  $500\Omega$ .

The integration of this pot in the schematic will look like: Another way of volume control would be giving

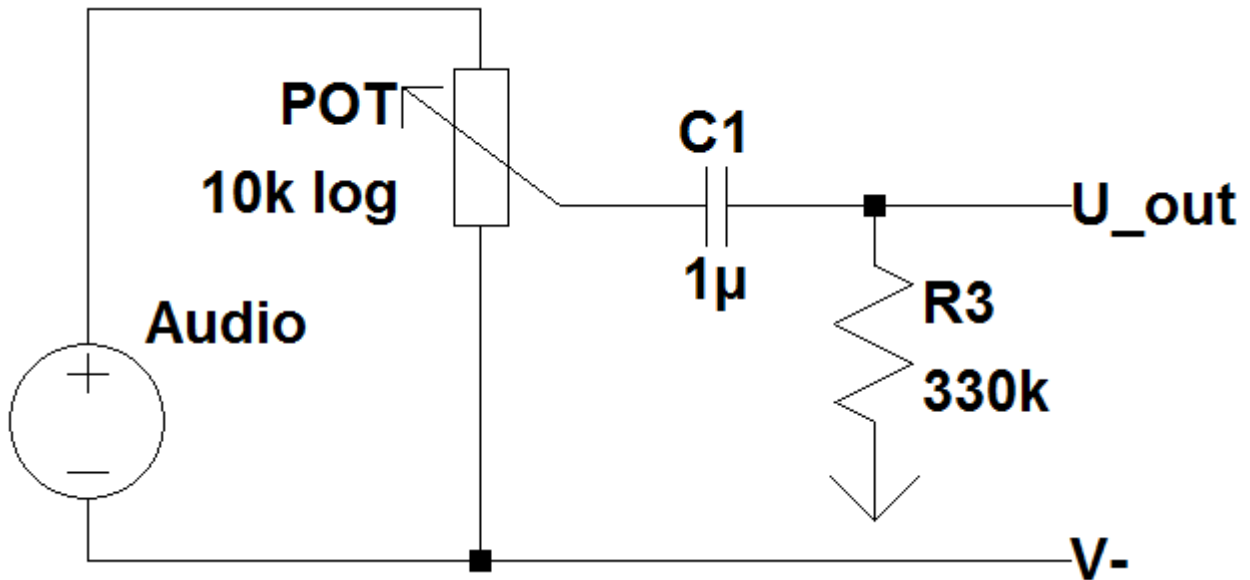

the amplifier a variable gain. It is also possible to swap R1 in the basic design for a potentiometer of the same value. This will keep your input impedance high, but your amplification range will be adjustable from 1 to 34.

## 10.5 Bridging

A very effective way to increase the output power, without increasing the supply voltage, is called "bridging". The principle of this is to steer the load (in this case a speaker) between two amplifiers, instead of between one amplifier and a fixed reference (ground). In the basic amplifier, the voltage range (neglecting significant voltage losses in the operational amplifier and the push pull pair) is approximately 0 to  $U_{CC}$ , a voltage sweep of  $U_{CC}$ . When steering between two amplifiers, the output range is the difference between two amplifiers: from  $U_{CC} - 0$  to  $0 - U_{CC}$ , a sweep of  $2U_{CC}$ . With this double output sweep, the power of this amplifier is quadrupled. To integrate this bridging into the basic system, a second amplifying half is added. The schematic for the bridged amplifier could be as follows:

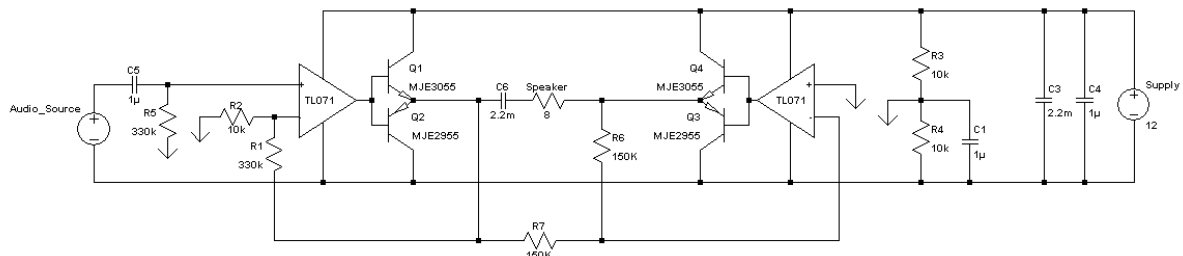

Notice the added right half is an inverting amplifier with an amplification factor of -1, its input signal at the output of the left amplifier (left of C1) and its feedback point at the output of the right amplifier (right of

the speaker). In this configuration, the left half still amplifies with a factor 34, and the right half amplifies this signal with a factor -1. Effectively, one side of the speaker is steered with 34x the input signal, and the other half with -34x the input signal, thus doubling the voltage difference. This modification therefore also doubles your voltage amplification (your total amplification is now 68). If you want to keep the amplification the same, change the resistor values in the feedback loops.

The capacitor near the speaker prevent a DC current from running through the speaker, due to a usual unbalance between the amplifiers.